

# Installation Instructions

## Cavity Slider with SmartMount



CS Full-Height detail enables the underside of the track to finish flush with the underside of the ceiling. This gives the appearance of the ceiling running continuously from one room to another, creating a more spacious feel.

### General Notes

- ▮ Units should be installed completely **before** the ceiling is fitted. Take care to ensure installed track height suits ceiling installation (see note 1).
- ▮ Install the unit as per the standard instructions supplied.

### Installation Notes

- 1 Ensure underside of track is level with the underside of the J-Mould. This may require the underside of the track to finish 1-2mm below the underside of the ceiling **before** stopping.
- 2 Check lining thickness used.  
10mm lining: leave MDF packer in place.  
13mm lining: remove packer.
- 3 Fit J-mould (not supplied) along opening of doorway. Cut lining in and fix.
- 4 Plaster and finish, taking care to keep the inside of track free of dust and paint splatter by opening the door(s) fully and masking the track slot(s).

### Additional Options

#### 1. Reduced Clearance Above Door

A gap of 3mm above the door can be achieved if requested at time of order. The unit will be supplied with a taller door and shorter hanger pins on the carriages. The mounting plate should be rebated into the top of the door.

#### 2. Standard Full-Height Units (WITHOUT SOFSTOP)

The red sleeve needs to be removed from the M8 wheel so that the minimum clearance can be achieved.

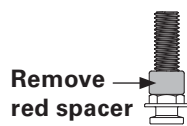

#### 3. SofStop

If your cavity slider is soft close and/or soft open, the front carriage will be supplied with a shorter (31mm) hanger pin (supplied in the SofPack box).

This will ensure the hanger pin doesn't interfere with the SofStop activator in the track.

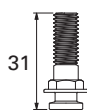

#### 4. CS BraceWall units

Ensure you fix through the centre of the track through all the pre-drilled holes.



↑ View looking up at OvertakingDoors x3 Full-Height track. If requested at time of order this track may be painted to match the ceiling finish more closely. Note how the underside of the track finishes flush with the underside of the ceiling.

### Full-Height Fixing Detail

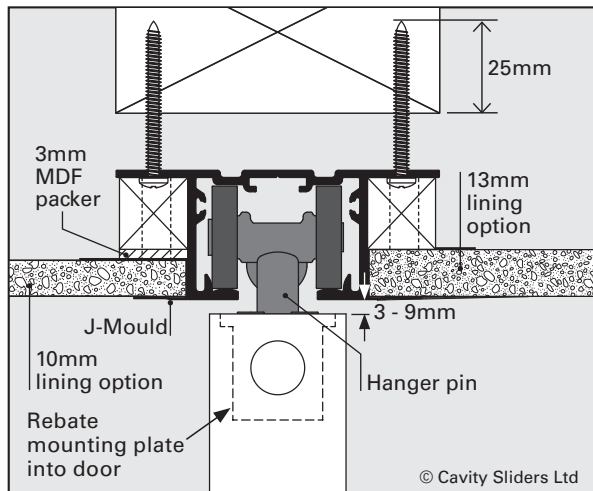

### Close up of Fixing Detail

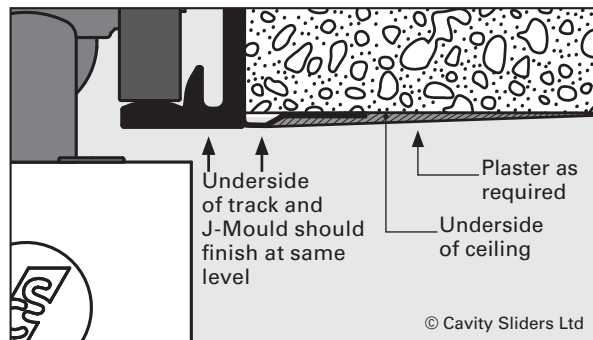

## IMPORTANT

Original track slot width must be maintained when lining ceiling to ensure smooth running.

